

Technics SL-1200MK2

Quartz Synthesizer Direct Drive
Turntable



Technics QUARTZ
Direct Drive Turntable System SL-1200MK2

QUARTZ

Professional Series



For a Surprisingly Moderate Investment, You Can Now Own a Quartz Direct Drive Turntable with Studio Quality Performance.

When Technics introduced the original SL-1200 direct drive turntable several years ago, it made all other turntable drive systems seem antiquated in comparison. The SL-1200 became a strong favorite among audio purists, amateur and professional. It was particularly popular in discos because of its rugged construction, easy handling, high torque and good immunity to feedback.

The SL-1200MK2 represents the next generation, incorporating numerous improvements over the original. In addition to being quartz-locked direct drive, it permits continuous speed adjustment under quartz control (within a range of $\pm 8\%$). This feature will be appreciated by disco DJ's who wish to maintain consistent rhythm when changing records. Its starting torque is a high 1.5 kg·cm (1.3 lb-in), with the platter reaching rated speed within 0.7 second from standstill. It also maintains a tighter lock on the selected speed than did the original SL-1200. The SL-1200MK2 should also be virtually feedback-proof because of its special base design. The platter itself is damped on both sides to avoid ringing.

Block diagram

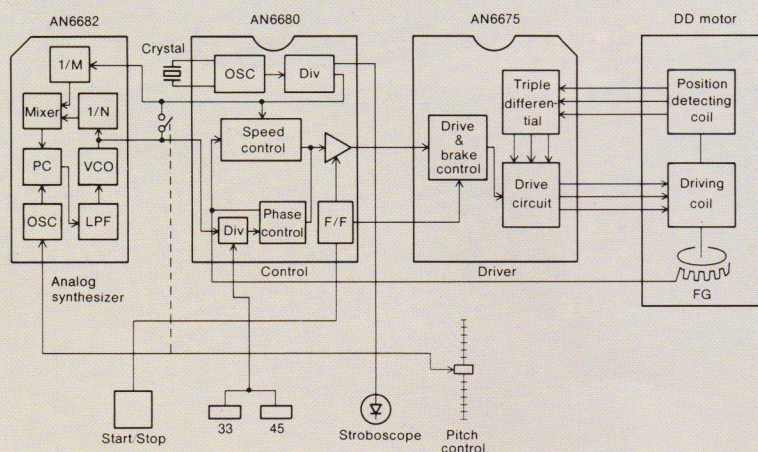

Total Quartz Locked Continuous Pitch Adjustment within $\pm 8\%$

Quartz-phase-locked control means almost perfect accuracy of turntable rotation.

But with most quartz turntables, this accurate control circuit must be cut out when the pitch control is employed. (Technics own SL-1300/1400/1500MK2 series, and SP-15 and SP-25 are among the rare exceptions.)

With the SL-1200MK2, however, pitch is variable continuously (analogically) by up to $\pm 8\%$ under total quartz-locked control. The pitch is controlled with a large sliding lever, located to the right of the turntable platter.

Four lines of platter markings are also provided indicating $+6\%$, $+3.3\%$, 0% (exact rated speed) and -3.3% change from rated speed. When exactly on speed, a green light illuminates.

Aluminum Diecast Cabinet and Special Heavy Rubber Base Material Provide Acoustic Isolation

The effects of external vibrations are dramatically reduced in the turntable by this new turntable construction.

The turntable base is precision-made aluminum diecast. And the underside of the main base is made of a heavy rubber material (special one-piece molding) which has excellent vibration resistance and absorbing characteristics. The turntable platter is also vibration-damped with specially fabricated rubber matting in the underside along with the thick turntable sheet (rubber mat). Four large-size insulating feet also help to absorb unwanted vibrations.

These features make SL-1200MK2 ideal for use with extra-high sound pressure levels.

High Torque for Fast Starts

The integral rotor/platter motor delivers 1.5 kg-cm (1.3 lb-in) starting torque. This high torque gives very quick starts enabling the platter to reach 33-1/3 rpm within 0.7 sec. (a quarter of a turn). This is a big advantage in many professional applications where fast cueing is a necessity.

Start-up time

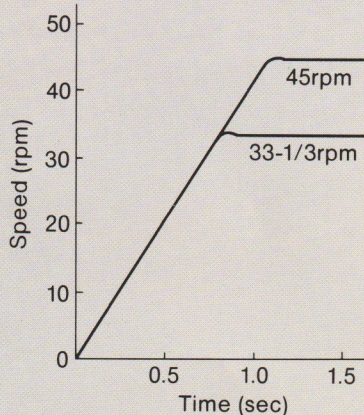

Cross section of SL-1200MK2

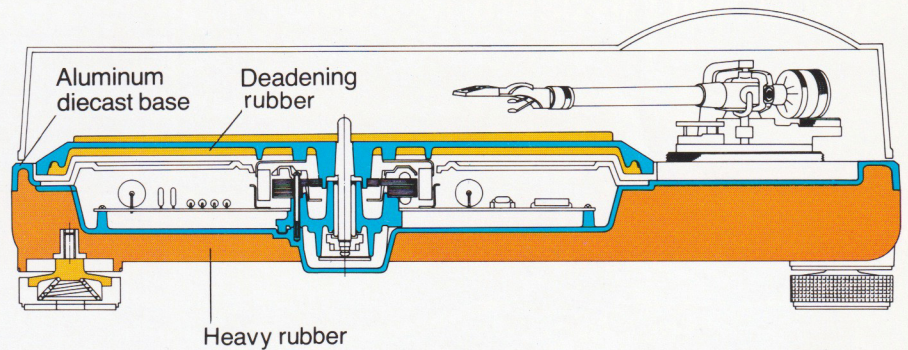

Stylus Illuminator for Low-Light Conditions

You'll appreciate the stylus illuminator when you are using the turntable under low-light conditions. The illuminator can be hidden in the turntable base. Should you need it, simply push a button and it will pop up gently and cast a beam of light across the disc in the area traversed by the tonearm. You can then clearly see the spaces between the selections on the record, and cue the arm exactly where you want it. The illuminator can then be pushed back down into the base.



computer designed, light-weight, high-rigidity headshell made of single-piece diecast aluminum to resist partial vibration. The universal design allows headshell interchangeability. Contacts are gold-plated.



Helicoid Tonearm Height Adjustment

Arm height is adjustable within a range of 6 mm to accommodate varying cartridge dimensions. Adjustments are done with a precision-made helicoid.

High Sensitivity, Low Mass, Gimbal Suspension Tonearm

The highly sensitive tonearm features a genuine gimbal suspension, the rotational center of which is precisely defined at one point. Bearings are finished to a tolerance of ± 0.5 microns. This, and the extra-closeness of pivot center to the bearings, result in the minimal friction of 7 mg (0.007 g) for both horizontal and vertical movement. Add to this the low 12-gram effective tonearm mass (including headshell, without cartridge) and you have a tonearm compatible with the wide range of compliances found in today's cartridges. If you choose a popular high compliance MM cartridge, the low range resonance frequency will appear in the correct area to avoid warp frequencies of records, but without entering the low end of the audio spectrum. This tonearm is provided with a

Other Fine Features

- Quick stops are achieved with a fully electronic braking system.
- A strobe illuminator is provided. The stroboscope is controlled by the extremely stable quartz oscillator, rather than potentially unstable AC line frequency.
- Power on/off control built-into strobe illuminator for ease-of-operation.
- Soft-touch start/stop switch allowing precision control capability without the annoyance of accidental operation.
- Technics integral rotor/platter motor construction with full cycle detection FG.



Technical Specifications

TURNTABLE SECTION

Type	Quartz Synthesizer Direct Drive Manual Turntable
Motor	Ultra-low-speed brushless DC motor
Turntable platter	Aluminum diecast, diameter 13-5/64" (33.2 cm) weight 4.4 lb (2 kg) (including rubber matting)
Turntable speeds	33-1/3 and 45 rpm
Pitch controls	All quartz-locked control within $\pm 8\%$ range
Starting torque	1.3 lb-in (1.5 kg-cm)
Start-up time	0.7 sec (90° rotation) to 33-1/3 rpm
Braking system	electronic brake
Wow and flutter	0.01% WRMS* 0.025% (JIS C5521) $\pm 0.035\%$ peak (IEC 98A weighted)

Rumble	-56 dB DIN A (IEC 98A unweighted) -78 dB DIN B (IEC 98A weighted)
--------	--

TONEARM SECTION

Type	Universal S-shaped tubular arm, static-balanced type, with anti-skating force control device, oil-damped cueing device in both directions
Effective length	9-1/16" (230 mm)
Overhang	19/32" (15 mm)
Tracking error angle	+0°32' at the inner groove of record +2°32' at the outer groove of record
Friction	7 mg (lateral, vertical)
Effective mass	12 g (without cartridge)
Offset angle	22°
Tonearm height adjustment	6 mm

Adjustable tracking force	0~2.5 g
Cartridge range	6~9.5 g 3~6.5 g (with addition of included weight)
Headshell weight	7.5 g

GENERAL

Power supply	AC 120 V, 50/60 Hz
Power consumption	12W
Dimensions (H×W×D)	6-19/64"×17-27/32"×14-11/64" (16.2×45.3×36.0 cm)
Weight	24.3lb (11 kg)

* This rating refers to turntable assembly alone, excluding effects of record, cartridge or tonearm, but including platter.
Measured by obtaining signal from built-in frequency generator of motor assembly.

Technics

Panasonic Company
Division of Matsushita Electric Corporation of America
EXECUTIVE OFFICES: One Panasonic Way, Secaucus, New Jersey 07094 (201) 348-7000
PANASONIC NEW YORK: 50 Meadowlands Parkway, Secaucus, New Jersey 07094 (201) 348-7000
PANASONIC NEW JERSEY: 50 Meadowlands Parkway, Secaucus, New Jersey 07094 (201) 348-7000
PANASONIC BOSTON: 75 University Avenue (P.O. Box 487, Norwood, Mass.), Westwood, Massachusetts 02090 (617) 326-4000
PANASONIC BALTIMORE: 11 Azar Court, Baltimore, Md. 21227 (301) 247-4300
PANASONIC CHICAGO: 425 East Algonquin Road, Arlington Heights, Ill. 60005 (312) 364-7900
PANASONIC ATLANTA: 1 Meca Way, Duluth, Georgia 30136 (404) 448-1100
PANASONIC DALLAS: 1825 Walnut Hill Lane, Irving, Texas 75062 (214) 258-2828
PANASONIC WEST, INC.: 8383 Wilshire Blvd., Beverly Hills, Calif. 90211 (213) 655-1111
PANASONIC SALES COMPANY: Ave. 65 de Infanteria, Km. 9.7, Victoria Industrial Park, Carolina, Puerto Rico 00630 (809) 769-4320
PANASONIC HAWAII, INC.: 320 Waiakamilo Road, Honolulu, Hawaii 96817 (808) 847-5361